



PRI Blueprints



Co-funded by
the European Union

Table of Contents

INTRODUCTION	3
BUILDING BACKGROUND	4
DRAWING DICE	5
IDEA	5
MATERIAL	6
ACTIVITIES	6
FRUIT HARVESTING	7
IDEA	7
MATERIAL	7
ACTIVITIES	8
THE BEAVER'S DAM	10
IDEA	10
MATERIAL	10
ACTIVITIES	11
THE SEESAW	13
IDEA	13
MATERIAL	13
ACTIVITIES	14
LOOKING FOR AN EQUILIBRIUM	15
IDEA	15
MATERIAL	15
ACTIVITIES	16
REPRESENTING NUMBERS	17
IDEA	17
MATERIAL	17
ACTIVITIES	18

Introduction

Mathematics is a crucial element of STEAM subjects and one of the principal skills required at the moment, and that will be needed in the future to awaken scientific vocations among young people.

The acronym SMEM used for this project means "Significant Mathematics for Early Mathematicians." The SMEM project has taken on a multidimensional approach that aims to create a new space for innovative teaching methods in mathematics, reduce the gender gap related to STEM-oriented pathways, cultivate a variety of soft and human-centric skills, and foster a positive image of mathematics as a subject.

We designed the exhibition for children between three and eight years of age, their teachers, and anyone interested in bridging the gap between mathematics and play. The blueprints contain the original ideas for each exhibit, the thinking process, necessary materials for building the exhibits, appropriate activities, and their connections to mathematics.

Building Backgrounds

Although the SMEM exhibition comprises six stand-alone exhibits, a beautiful background story connects them. It has a forest theme, and Emy, the fox, is the main character.

We crafted a gorgeous background for each exhibit with lovely illustrations, an appropriate tale, and valuable advice. We encourage you not to build the exhibits alone but also to include the background stands.

Material:

- 2 Wooden board (e.g., plywood) or thick cardboard with dimensions 42cm x 60 cm
- Ground plate with dimensions (big enough to fit two slits 42cm long at an angle of 150°)
- 4 wooden cuboids with dimensions 42cmx2cmx2cm

Print background on paper/PVC/etc.

Take the wooden boards (or thick cardboard) and sand the edges. Print the background on paper or foil and fix it on your boards. You can use double-sided tape, glue, or Velcro.

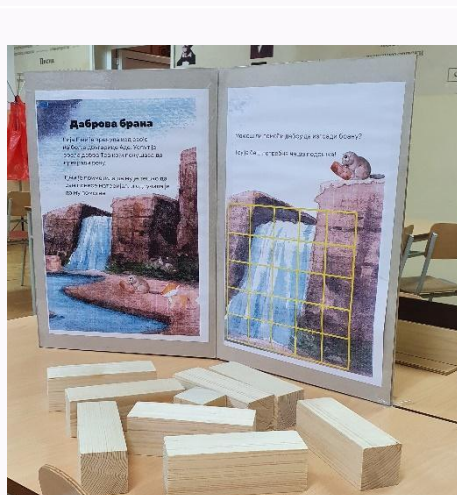

Drawing Dice

Idea

Winter is long in the woods. Sometimes, Emy and her friends, who don't hibernate, find themselves in one of their lairs, telling stories, singing songs, or playing games.



One of the games they like the most is to create pictures with the four dice that a goblin gave to Emy. They only look at the top side of the dice.

The dice have the same shapes drawn on the six faces.

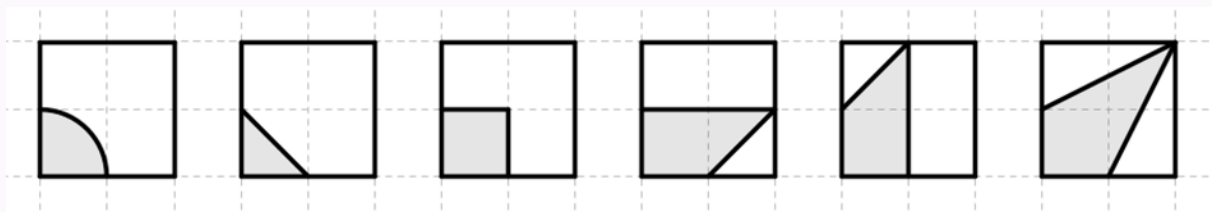

The shapes still allow everyone to draw many different figures and invent new ones.

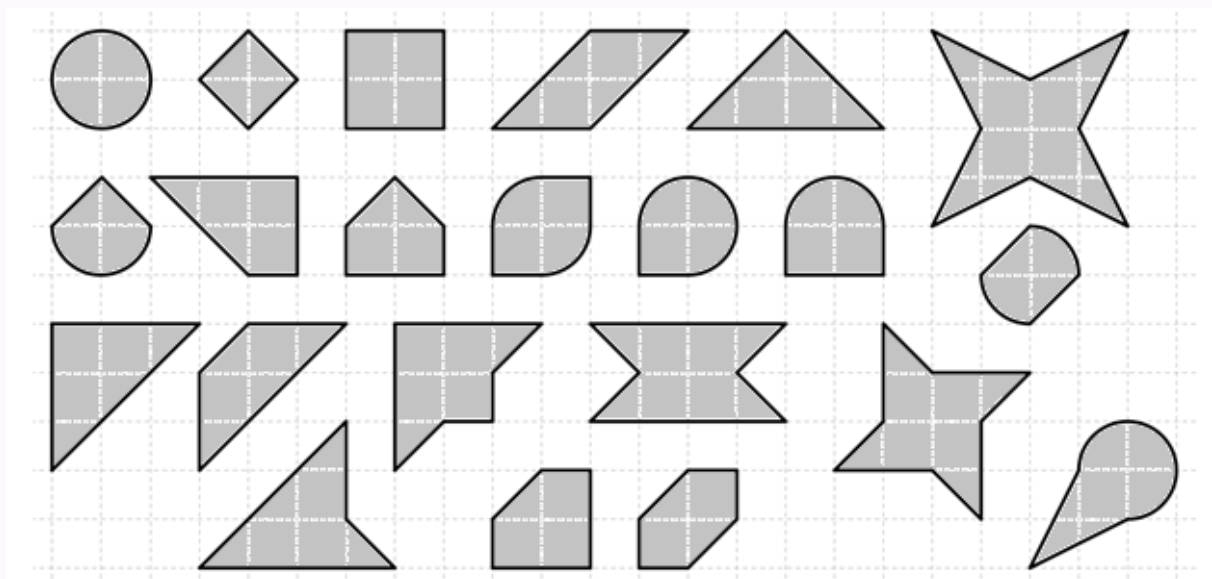

As can be seen from the picture of the first prototype created, the drawing of the faces can be reduced to a simple line. It allows you to assemble many and more varied images. It is a prospect that could be considered for the next level workshop, designed for older pupils, making dice with lightweight cardboard.

However, we consider it crucial that for the first engagement with the exhibition materials, especially when working with young kids, you use the dice with the dark area that stands out, so it is clear which part belongs to the figure to compose (the dark parts) and which one should be considered as negative space (the light ones).

Material

The four dice can be built (or purchased) from disparate materials: wood, plastic, etc.

The most suitable cube dimensions for easy handling are the sides of 4 or 5 cm.

You could paint the pictures directly onto the faces or use stickers or vinyl to create them.

You can find plastic cubes that contain small but powerful neodymium magnets inside. The activity of the magnets adds a certain amount of joy and a pleasant surprise that aids in motivating children.

Optionally, given their economical size, the dice can be produced with a 3D printer, inserting the magnets before assembling the faces.

It would not be hard to design the dice so that the coloured and neutral part of each face can be identified by touch, making the module suitable even for visually impaired users.

Activities

The exhibit provides a possibility to investigate the links between geometry and combinatorics. It also facilitates the classification of shapes, the perception of dimensions, and spatial orientation.

The activity itself does not require any instructions. Nevertheless, a dialogue between the kids alone or between an educator and children could enrich it additionally.

The dialogue and the mathematical content of the activity could be further enhanced if the exhibition offered two sets of dice so that two groups could produce their works simultaneously to be able to compare them (shapes, perimeters, areas, etc.).

Skills/competencies practiced within this activity include:

- Use a square grid to compute angles, lengths, and areas without the help of measuring tools.
- Work on finding areas of simple 2D shapes.
- Adopt the notions of conservation of the area and area decomposition.
- Practice mental arithmetic: products and additions.
- Work on combinatorial challenges regarding the combination of dice faces.
- Comprehend the concepts of change of scale and proportionality of lengths and areas.

Fruit Harvesting

Idea

The two squirrels, Danny and Johann, are very fond of cherries, but today, they don't want to eat the fruit at all but want to bring some to their friends. The basket that a squirrel can carry cannot be huge and can hold only a few cherries, gathered alone or in groups of two, three, and even four fruits.

Can you help the two squirrels arrange them neatly in their baskets?

The rule is to use all the cherries and fill the first basket. Then, fill the second one by using all the cherries again.

Material

For this activity we need:

- Cherries, with the following distribution:

Number of cherries	1	2	3	4	
Number of copies	3	2	2	2	
Total cherries	3	4	6	8	21

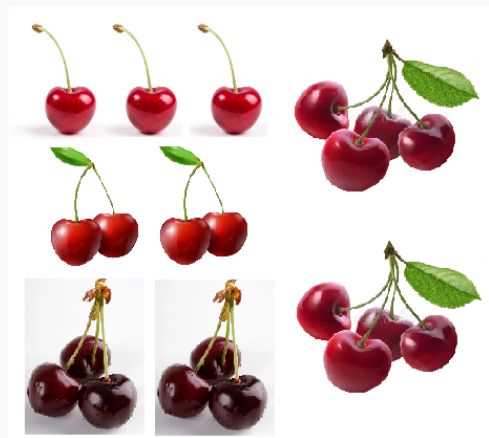

- Two baskets with a distinct distribution of 21 holes (each basket should have a diameter of 28 to 30 cm with 21 holes. They each have a diameter of 7,5 to 8 mm and are at a distance of 30mm).

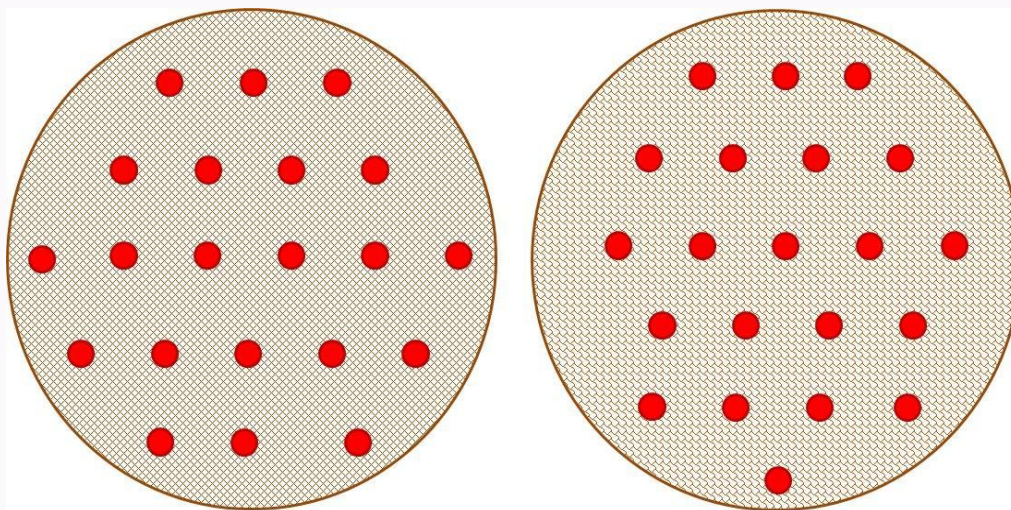

For the construction, two DIN A3 PVC panels are utilized (alternatively, you could use wooden boards), with each board structured as follows:

- The bottom layer is crafted from a 3 mm thick PVC sheet, displaying drawn red circles.

- The top layer, also made of a 3 mm thick PVC sheet, exhibits a basket illustration with holes precisely matching the red circles on the bottom layer. The cherry groups will be placed in these holes.

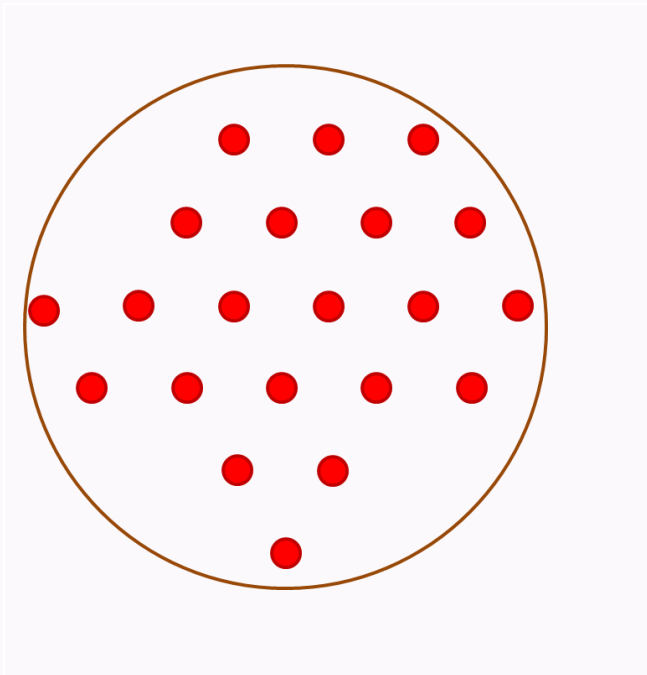

You could simulate cherries with wooden balls of 30 mm in diameter. They suffice for single cherries, while for grouping them into two, three, and four pieces, you could connect them with wooden pegs.

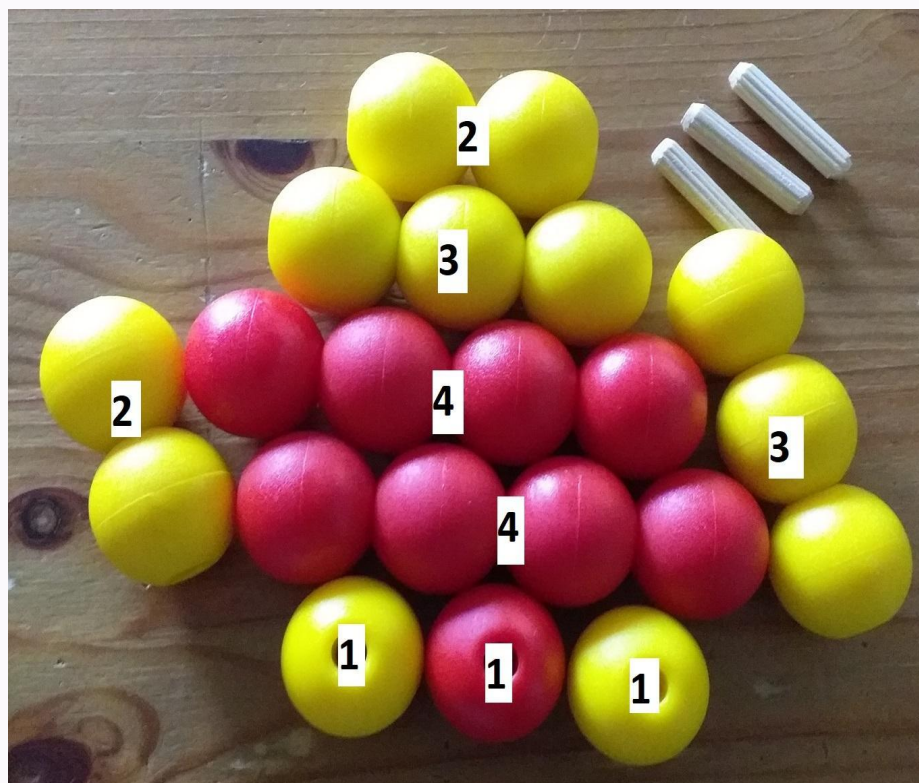

Activities

This exhibit makes the possibility of arranging cherries in baskets in various ways explicit. Each basket can have distinct groupings of cherries. Even after solving the challenge, kids can still explore alternative layouts.

Furthermore, you could set up instant challenges in a workshop style, such as:

"Avoid using the set of three cherries to fill the trio of holes" or a similar restriction.

The principal abilities that the exhibit stimulates include number composition and fast mental calculus.

The fact that there are several exact solutions stimulates the habit of not being satisfied with the first solution, even if it is correct, but to continue with investigations.



The Beaver's Dam

Emy is on her way to Ada, her best friend when she meets Teo. He is a beaver and struggling with building his dam. Emy decides to help Theo with his problem of arranging nine wooden logs such that they cover a square area.

Idea

Your task is to build a dam (in the form of a wall) with a height and width of five units (and a depth of one unit). The bricks given have the following dimensions: 8 orthogonal parallelepipeds with dimensions $1 \times 1 \times 3$ and one cube with the side of one unit.

Only one unique solution exists - the small cube has to be in the middle of the dam.



Fig.: Vertical beaver's dam (rough prototype)

Material

There are several ways to create the elements needed for this activity. We suggest using wood as the ultimate material and one of the following ways to make beaver's logs:

1. Take a piece of wood measuring more than $7 \times 35 \times 35 \text{ cm}^3$. Cut out eight parallelepipeds measuring $7 \times 7 \times 21 \text{ cm}^3$ and one cube with a side of 7 cm . Smooth the edges with sandpaper for a polished finish.
2. Take 25 wooden cubes of identical volume with a recommended side length of 7 cm . Glue three cubes together to form a $1 \times 1 \times 3$ parallelepiped, and repeat this process eight more times. Polish the surfaces with sandpaper for a sleek look. Add a pop of colour by painting all the parallelepipeds in one shade, reserving another colour for the remaining cube.
3. Opt for a lighter version with hollow bricks. For each parallelepiped, obtain four (wooden) plates measuring $0.3 \times 21 \times 6.7 \text{ cm}^3$ —totaling 32 plates. Additionally, gather 18 plates with dimensions $0.5 \times 6.4 \times 6.4 \text{ cm}^3$ that will become the base of both parallelepipeds and the

cube and four plates measuring $0.3 \times 7 \times 6.7 \text{ cm}^3$ for the sides of the cube. Assemble the pieces by gluing them together, positioning the thicker plates (0.5 cm) as end pieces on opposing sides. Align four parts of the same length around these bases, slightly overlapping on one side (3 mm). Continue gluing segments until you use all the wood components, creating a unique and hollow design.

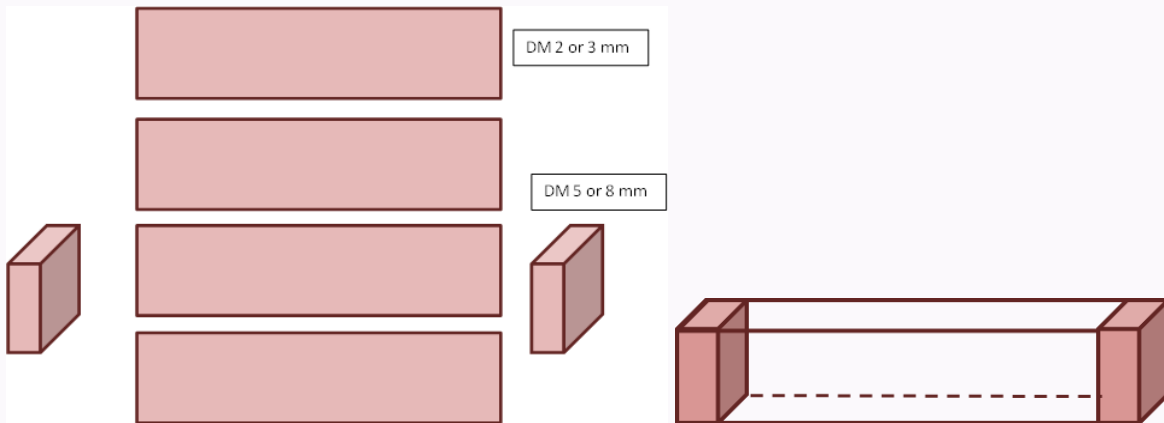

Pilot tests have shown that we need a 5x5-grid that will clearly indicate how the dam should look like (see the following picture).

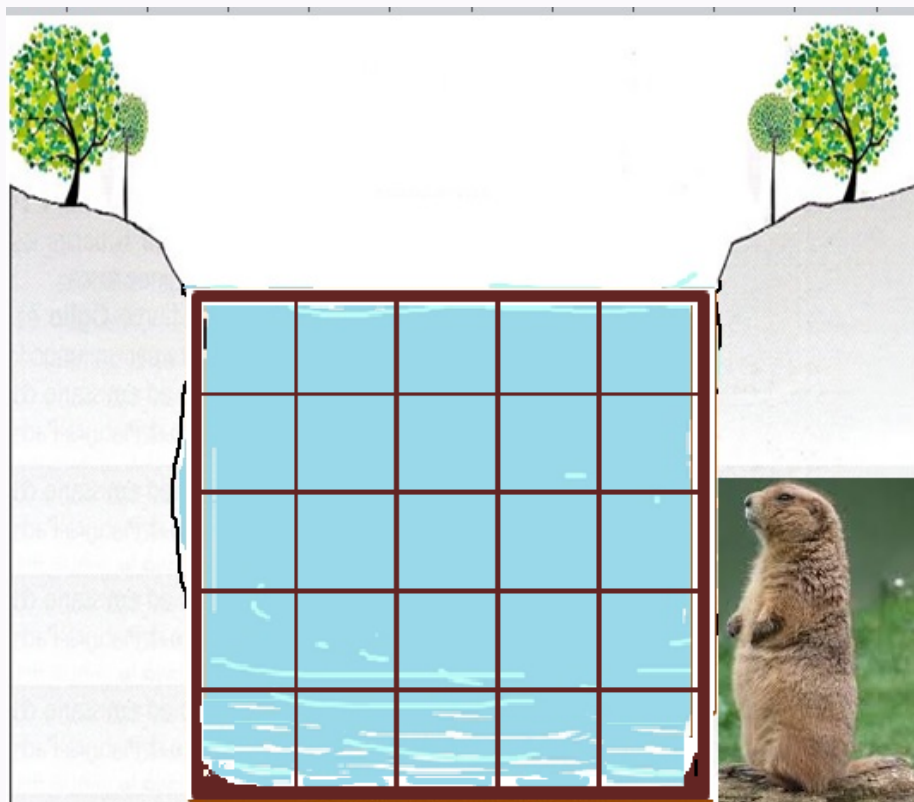

Activities

This exhibit provides a mighty relationship between geometry and combinatorics.

- (a) How to build the dam is not clear at all. A helpful hint could be: "Where should we put the cube?"

- (b) Imagine a baby beaver's dam. It consists of four 1x1x2 bricks and one 1x1x1 cube. You should build a dam with a height and width of three units. Where can you place the cube in this case?
- (c) On a higher level, you can logically exclude some of the positions. For instance, the cube cannot be in the bottom left-hand corner. Assume you put it right there. Then, parallelepiped might be positioned vertically on the top of the cube, or you could put it horizontally next to it. Suppose the latter is the case. That would mean a vertically placed parallelepiped must cover a lower right-hand corner.

You might consider this investigation also from a higher mathematical point of view. For this, accept the following colouring of the (front of the) beaver's dam.

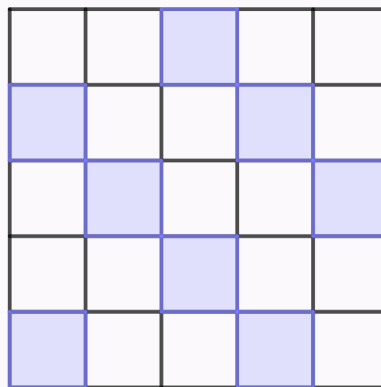

Observe the eight coloured cells and notice that each brick, wherever positioned in a hypothetical beaver's dam, covers exactly one coloured cell. Now, assume that you put the cube over one of the coloured cells. Then we are left with only seven coloured cells, and we could place only seven parallelepipeds in the grid – too few to cover 25 cells. As a consequence, you cannot put the cube on any of the coloured cells. So, the only (theoretical) possibilities for placing the cube in the grid are the white cells.

Rotate the pattern by 90°. As a result, some previously uncoloured cells will turn blue, and the cube cannot be positioned by covering any of them. If you rotate the pattern twice more, you'll observe that the only viable cell remaining for placing the cube is the one at the centre of the grid.



The Seesaw

Emy and her friends managed to build a seesaw. They are having fun trying it out and finding out how it works. They notice that a seesaw can balance even with different weights on each side.

Idea

Balancing a seesaw involves placing pieces on both sides until it levels.

In a quantitative rendition of this experiment, weights are represented by 1-, 2-, and 4-unit cubes. Solving the challenge of balancing a 4-unit cube with a 2-unit cube depends on examining the distances of these weights to the seesaw's midpoint.

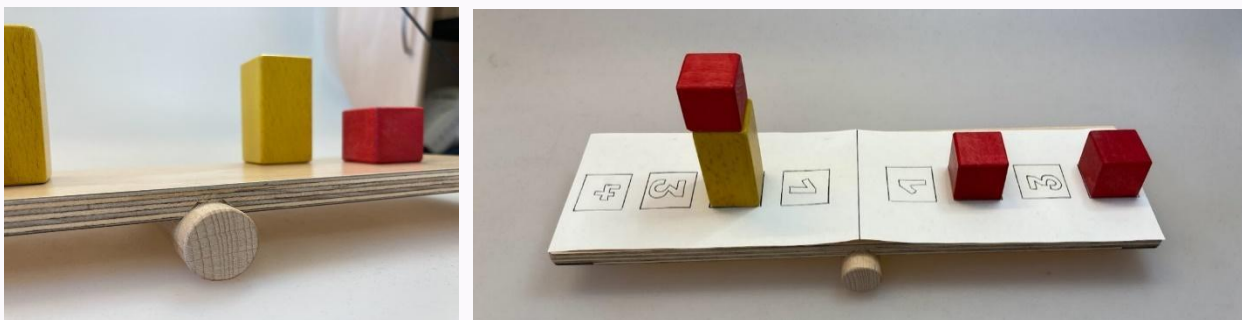
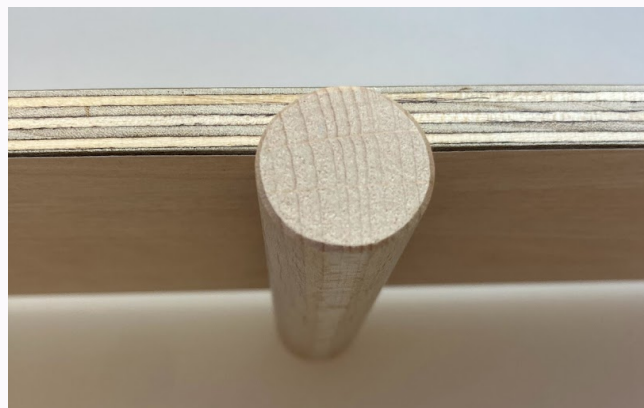

Fig.: Rough prototype

Material

For the seesaw, you need a plate measuring 50cm x 15cm with a round rod of 1.5cm diameter fixed precisely in the middle.



Sand the rod at its lowest point to ensure it lies on a small flat surface. Write numbers 1-4 on top of the seesaw, each surrounded by a cube with a side of 2.5cm. Alternatively, separate them with lines.

Put one unit cube on an arbitrary number n on one side of the seesaw. If you place n/m unit cubes on number m of the other side of the seesaw, the seesaw is in balance. In the following template, you will get the exact placements of the boxes for a 50cm long seesaw.

The data is missing!

For weights, consider wooden or plastic cubes. We suggest using 30 wooden cubes with sides of 2.5cm, along with six cuboids measuring 2.5x2.5x5cm³ (formed by gluing two cubes together)

and three cuboids measuring $2.5 \times 2.5 \times 10 \text{ cm}^3$ (formed by gluing four cubes in a line). Optionally, distinguish between weights using colors (e.g., 1-unit cubes in yellow, 2-unit cuboids in red, 4-unit cuboids in blue).

Ensure uniform weight for all cubes. Also, weigh the glued cuboids and, if exceeding two or four times the small cube's weight, sand them down to match two or four times a small cube's weight.

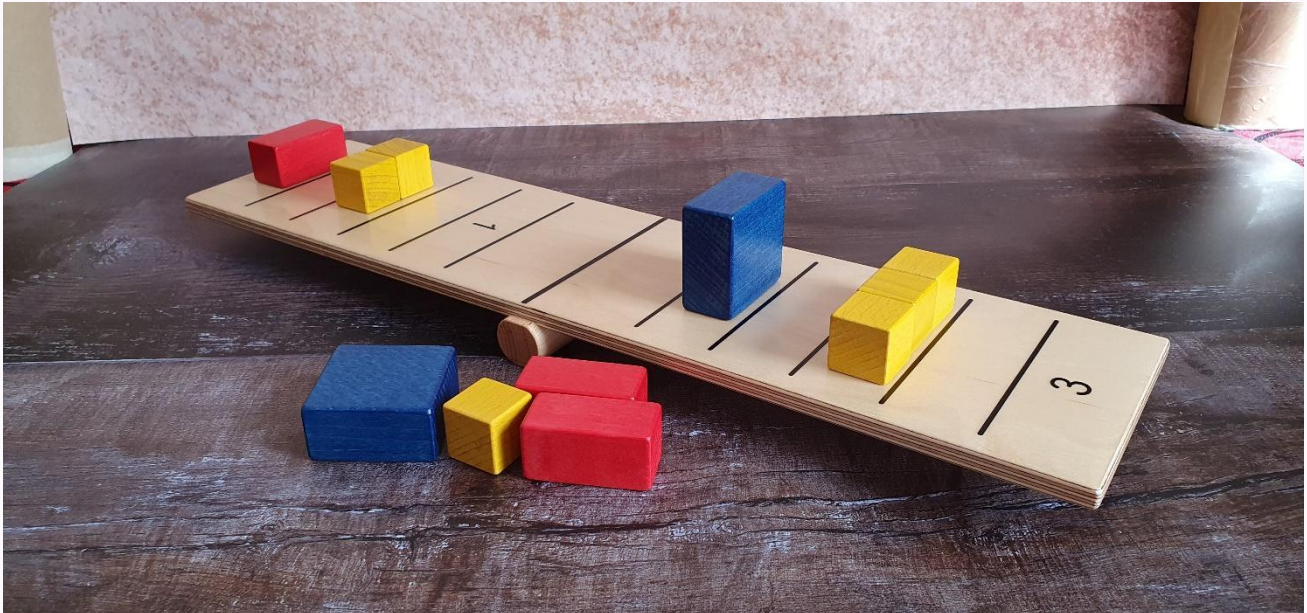

Activities

1. Upon encountering a balance, be it a child or an adult, the instinct is often to distribute items on both sides, aiming for equilibrium. Despite its simplicity, this approach raises questions
 - Does the number of pieces play a role?
 - How does one counterbalance a heavier piece with lighter ones, and how many are needed?
 - Does the positioning of pieces affect the equilibrium?
2. Exploring the quantitative perspective, it becomes evident that the crucial idea revolves around the combination of weight and position. Commencing with elementary questions, one might wonder about the possibility of balancing a "weight 2" piece with just one "weight 1" piece and their appropriate placement. Subsequently, more intricate questions arise:
 - By placing one cube (of one unit weight) on each of positions 1 and 2 on one arm, can equilibrium be established with just one cube?
 - With one cube on each of positions 1, 2, and 3 of one arm, can equilibrium be established with just one cube? Can equilibrium be reached with just one "weight 2" piece?
3. At the core, the lever law provides the background theory, affirming that equilibrium in the balance is achieved if and only if the sum of the products "distance from the midpoint times weight" is equal on both sides.

Looking For an Equilibrium

J.R. the bird wants to play a game with Emy the Fox. The goal is to balance different objects on the top of the fence.

Idea

Arrange multiple two-dimensional objects along a horizontal line to prevent them from falling.



Fig.: Rough prototype

Material

One wooden ground plate (36cm x 12cm x 1cm)

Two wooden cuboids (30cm x 2cm x 2cm)

One wooden vertical plate (30cm x 12cm x 0.7cm)

Different shapes (see examples below) made of thin wood, such as plywood.

To secure the ground plate, glue the two cuboids to it, confirming they are precisely in the middle of the plate and have an 8mm distance from each other.

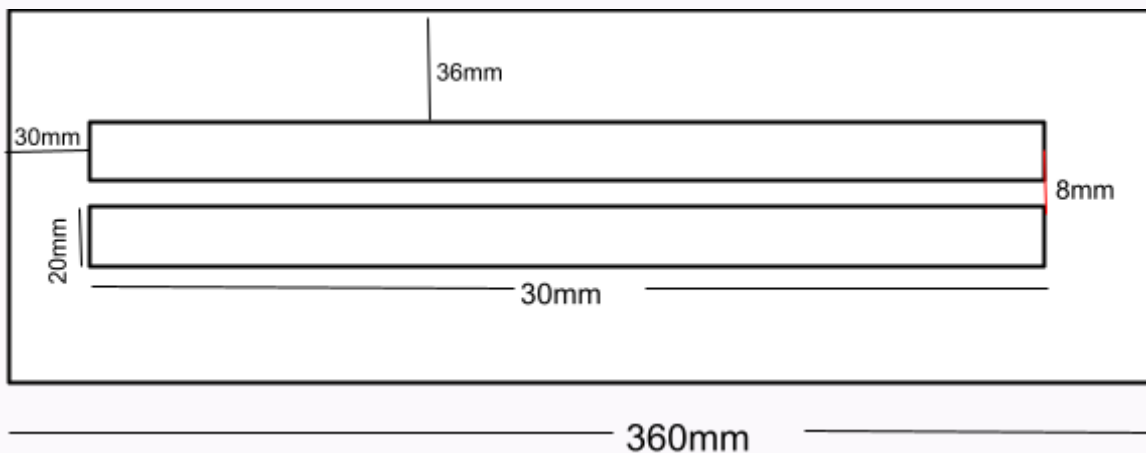

Insert the vertical plate into the ground plate, ensuring it maintains a 90° angle. It is crucial to easily balance symmetric figures

The following suggestions for shapes to be used are all symmetric with respect to a point.

Possible Shapes

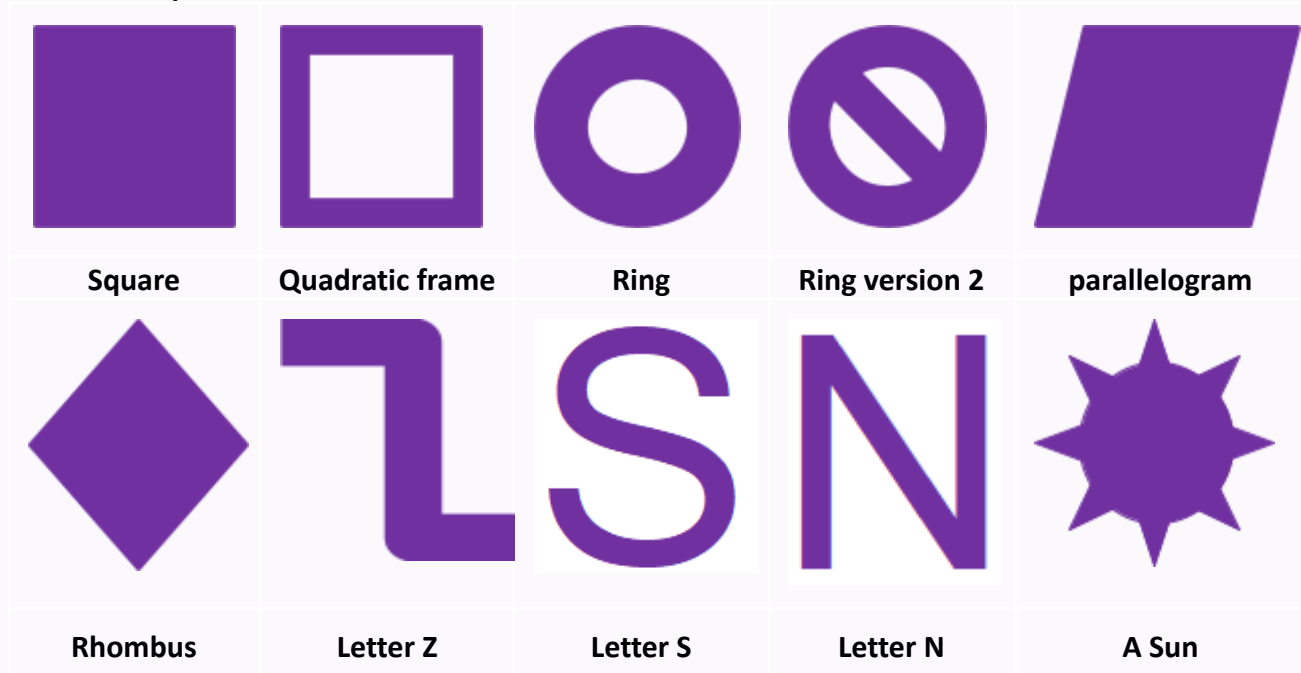

We restrict ourselves to figures which are symmetric with respect to a point. In the universe of these figures everything is easy: each line through the centre of gravity divides the figure into two equal halves.

Activities

1. Balancing objects poses a significant challenge for small children, prompting them to practice essential skills such as estimating distances and improving hand-eye coordination. This ability considered a vital process-related competence in the German curriculum, significantly contributes to children's advancement in mathematics.
2. Through the activity, children unconsciously absorb the characteristics of various figures. Some shapes, such as squares and rectangles, are deemed "easy" as they offer an "obvious" choice for a balancing line.
3. As they progress, children discover the numerous balancing lines and learn about the characteristics that distinguish these lines.
4. Additionally, children get the idea that some figures, like rings, can balance along a line but not on a point (because the figure's centre of gravity is physically not present).



Representing Numbers

Emy and her friends discover the forest around them! They notice the flowers, the trees, the animals, etc. Can you put the objects from the board centre to the correct place according to their number?

Idea

Associate a number with the representation of this number.

Material

You will need a hole saw or a laser cutter to make the board.

For the lower part, use a round wooden board with a thickness of 1 cm and a diameter of 60cm. For the upper part, prepare a second wooden board with the same diameter and thickness of 0.5 cm. You should also drill ten holes, each measuring ten cm in diameter, at specific positions, as depicted in the illustration.

You should also integrate three rods with a 0.5 cm diameter and length of 15 cm.



Glue the two boards together and place the rods for stacking support in the centre (you could glue them to the board, but it is better to fix them with a hole system).

Number the holes from one to ten in writing. Optionally, use vinyl or engraving.

Create tokens from a wooden board with a 1cm thickness. Cut out ten circles, each with a 10cm diameter. Attach a vinyl or sticker featuring a forest element on each token.

To set up the exhibit, arrange all tokens in the wrong order on a stack placed at the board's centre.

Optionally, produce objects with a 3D printer for placement at the board's centre or hide them in the classroom or the child's environment.





Activities

The child should take one token after another and place it in the hole corresponding to the number. While doing this, it turned out that a fruitful conversation between the kid and the educator could arise.

Therefore, this activity allows working on different mathematical notions, such as gaining the number and numeration sense, which relates to learning to count up to 10, recognize numbers, etc. Also, you could make this activity even more engaging by introducing illustrations that could represent more than one number (so, instead of unique, they generate multiple solutions). The discussions will have even more educational weight in that way.



Co-funded by
the European Union

Funded by the European Union. Views and opinions expressed are however those of the author(s) only and do not necessarily reflect those of the European Union or the European Education and Culture Executive Agency (EACEA). Neither the European Union nor EACEA can be held responsible for them.

[Project Code: KA220-BE-2I-24-32460]

IMAGINARY
open mathematics

mathematikum
Mathematik zum Anfassen.



FERMAT SCIENCE
Une autre idée des maths



mmaca

Museu
de Matemàtiques
de Catalunya